

Sample/Pre-Board Paper 15
Class X Term 1 Exam Nov -Dec 2021
Mathematics (Standard) 041

Time Allowed: 90 minutes Maximum Marks: 40

General Instructions:

1. The question paper contains three parts A, B and C.
2. Section A consists of 20 questions of 1 mark each. Any 16 questions are to be attempted.
3. Section B consists of 20 questions of 1 mark each. Any 16 questions are to be attempted.
4. Section C consists of 10 questions based on two Case Studies. Attempt any 8 questions.
5. There is no negative marking.

SECTION A

Section A consists of 20 questions of 1 mark each. Any 16 questions are to be attempted.

1. What is the HCF of smallest primer number and the smallest composite number?
 (a) 2 (b) 4
 (c) 6 (d) 8
2. The value of c for which the pair of equations $cx - y = 2$ and $6x - 2y = 3$ will have is
 (a) 3 (b) -3
 (c) -12 (d) no value
3. In Figure, ABC is an isosceles triangle right angled at C with $AC = 4$ cm, the length of AB will be
4. From an airport, two aeroplanes start at the same time. If speed of first aeroplane due North is 500 km/h and that of other due East is 650 km/h then the approximate distance between the two aeroplanes after 2 hours will be
 (a) 1890 km
 (b) 1120 km
 (c) 1640 km
 (d) 2240 km
5. Two dice are thrown together. The probability that sum of the two numbers will be a multiple of 4, is:
 (a) $\frac{1}{2}$ (b) $\frac{1}{3}$
 (c) $\frac{1}{8}$ (d) $\frac{1}{4}$
6. In the given figures, the measure of $\angle X$ will be

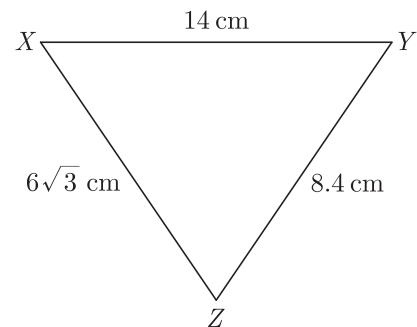
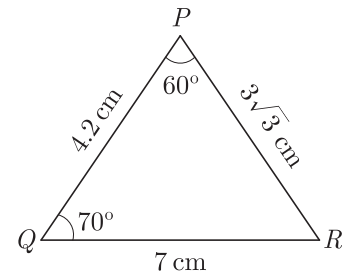
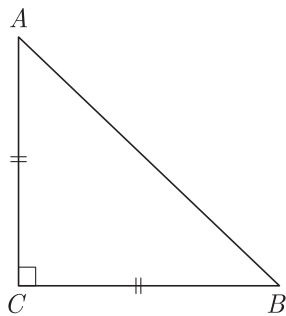

7. The value of $\left(\sin^2\theta + \frac{1}{1 + \tan^2\theta}\right) = \dots\dots\dots$
 (a) 0 (b) 1
 (c) 2 (d) 3
8. The least number which is a perfect square and is divisible by each of 16, 20 and 24 is
 (a) 240 (b) 1600
 (c) 2400 (d) 3600

9. What do you say about the following pair of linear equation ?

$$3x + 2y = 8, \quad 6x - 4y = 9$$

- (a) Lines are parallel
 (b) pair of linear equation is consistent
 (c) pair of linear equation is inconsistent
 (d) Lines are coincident
10. The distance of the point $P(2, 3)$ from the x -axis is

- (a) 2 (b) 3
 (c) 1 (d) 5

11. If -1 is a zero of the polynomial $f(x) = x^2 - 7x - 8$, then other zero is

- (a) 4 (b) 8
 (c) 1 (d) -4

12. What are the HCF and LCM of 16 and 36?

- (a) 4 and 9 (b) 9 and 4
 (c) 4 and 144 (d) 144 and 4

13. If θ be an acute angle and $5 \operatorname{cosec} \theta = 7$, then value of $\sin \theta + \cos^2 \theta - 1$ will be

- (a) $\frac{10}{49}$ (b) $\frac{39}{49}$
 (c) $\frac{10}{47}$ (d) $\frac{37}{47}$

14. If $\sqrt{2} \sin \theta = 1$, the value of $\sec^2 \theta - \operatorname{cosec}^2 \theta$ will be

- (a) 0 (b) 1
 (c) $\frac{1}{2}$ (d) $\frac{1}{4}$

15. The radius of a circle whose circumference is equal to the sum of the circumferences of the two circles of diameters 36 cm and 20 cm is

- (a) 56 cm (b) 42 cm
 (c) 28 cm (d) 16 cm

16. In the given figure, in a triangle PQR , $ST \parallel QR$ and

$$\frac{PS}{SQ} = \frac{3}{5} \text{ and } PR = 28 \text{ cm, the length of } PT \text{ will be}$$

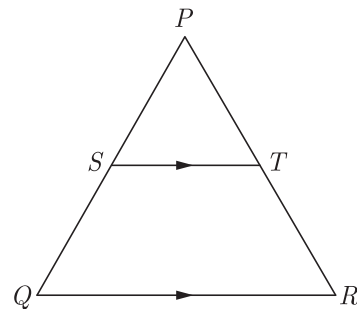

- (a) 21 cm (b) 10.5 cm
 (c) 15 cm (d) 15.5 cm

17. In Figure, in ΔABC , $DE \parallel BC$ such that $AD = 2.4$ cm, $AB = 3.2$ cm and $AC = 8$ cm, then what is the length of AE ?

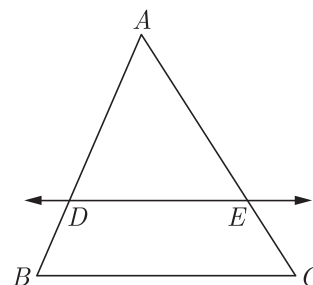

- (a) 2 cm (b) 4 cm
 (c) 5 cm (d) 6 cm

18. $\tan^2 30^\circ \sin 30^\circ + \cos 60^\circ \sin^2 90^\circ \tan^2 60^\circ - 2 \tan 45^\circ \cos^2 0^\circ \sin 90^\circ$

- (a) $\frac{2}{3}$ (b) $\frac{1}{3}$
 (c) $-\frac{2}{3}$ (d) $-\frac{1}{3}$

19. Given the linear equation $2x + 3y - 8 = 0$, select another linear equation in two variables such that the geometrical representation of the pair so formed is intersecting lines.

- (a) $5x + 2y - 9 = 0$ (b) $6x + 9y + 7 = 0$
 (c) $4x + 6y - 16 = 0$ (d) above all

20. What is the probability of an impossible event?

- (a) ∞ (b) 1
 (c) 0 (d) 0.5

SECTION B

Section B consists of 20 questions of 1 mark each. Any 16 questions are to be attempted.

21. 144 cartons of Coke cans and 90 cartons of Pepsi cans are to be stacked in a canteen. If each stack is of the same height and if it equal contain cartons of the same drink, what would be the greatest number of cartons

each stack would have?

- (a) 12 (b) 24
 (c) 18 (d) 36

22. The ratio in which the point $(2, y)$ divides the join of $(-4, 3)$ and $(6, 3)$, hence the value of y is
- (a) $2:3, y = 3$ (b) $3:2, y = 4$
(c) $3:2, y = 3$ (d) $3:2, y = 2$

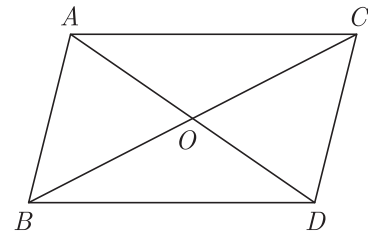

23. $\frac{2 \cos^2 60^\circ + 3 \sec^2 30^\circ - 2 \tan^2 45^\circ}{\sin^2 30^\circ + \cos^2 45^\circ} = ?$

- (a) $\frac{15}{7}$ (b) $\frac{10}{3}$
(c) $\frac{15}{8}$ (d) $\frac{10}{7}$

- (a) $\frac{DO}{AO}$ (b) $\frac{AO}{DO}$
(c) $\frac{DO+AO}{AO}$ (d) $\frac{DO+AO}{DO}$

24. What are the values of x and y for the following pair of linear equations ?

$$99x + 101y = 499 \text{ and } 101x + 99y = 501$$

- (a) 3 and 6 (b) 3 and 2
(c) 2 and 3 (d) 6 and 3

31. What is the ratio in which the line joining points $(a + b, b + a)$ and $(a - b, b - a)$ is divided by the point (a, b) ?

- (a) $1 : 1$ (b) $2 : 1$
(c) $2 : 3$ (d) $1 : 3$

25. If α and β are zeroes of the polynomial $f(x) = x^2 - x - k$, such that $\alpha - \beta = 9$, the value of k will be

- (a) 20 (b) 30
(c) 60 (d) 18

32. $\frac{\tan \theta}{1 - \cot \theta} + \frac{\cot \theta}{1 - \tan \theta} = ?$

- (a) $1 + \tan \theta \operatorname{cosec} \theta$ (b) $1 + \cos \theta \operatorname{cosec} \theta$
(c) $1 + \sin \theta \operatorname{cosec} \theta$ (d) $1 + \sec \theta \operatorname{cosec} \theta$

26. A bag contains 6 red balls and some blue balls. If the probability of drawing a blue ball from the bag is twice that of a red ball, what is the number of blue balls in the bag?

- (a) 10 (b) 12
(c) 14 (d) 16

33. What are the HCF and LCM of 510 and 92 ?

- (a) 4 and 16980
(b) 16980 and 4
(c) 23460 and 2
(d) 2 and 23460

27. A box contains 12 balls of which some are red in colour. If 6 more red balls are put in the box and a ball is drawn at random the probability of drawing a red ball doubles than what it was before. What is the number of red balls in the bag?

- (a) 3 (b) 4
(c) 5 (d) 6

34. In the figure, $PQRS$ is a trapezium in which $PQ \parallel RS$. On PQ and RS , there are points E and F respectively such that EF intersects SQ at G . Now the term $EQ \times GS$ is equal to

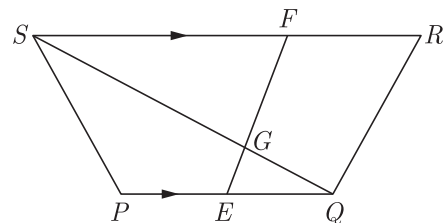

- (a) $GQ \times FS$
(b) $2GQ \times FS$
(c) $3GQ \times FS$
(d) $4GQ \times FS$

28. In an acute angled triangle ABC if $\sin(A + B - C) = \frac{1}{2}$ and $\cos(B + C - A) = \frac{1}{\sqrt{2}}$, measure of $\angle B$ is

- (a) 37.5° (b) 45°
(c) 75° (d) 62.5°

29. Select the mid-point of side BC of ΔABC , with $A(1, -4)$ and the mid-points of the sides through A being $(2, -1)$ and $(0, -1)$.

- (a) $(2, 4)$ (b) $(4, 2)$
(c) $(2, 1)$ (d) $(1, 2)$

30. In the given figure, ΔABC and ΔABC and ΔDBC are on the same base BC . AD and BC intersect at O .

Term $\frac{\operatorname{ar}(\Delta ABC)}{\operatorname{ar}(\Delta DBC)}$ is equal to

35. If the mid-point of the line segment joining $A\left[\frac{x}{2}, \frac{y+1}{2}\right]$ and $B(x+1, y-3)$ is $C(5, -2)$, value of y is

- (a) -1
(b) -2
(c) -3
(d) -4

36. What is the area of shaded region shown in the given figure? Here a circular arc of radius 6 cm has been drawn with vertex O of an equilateral triangle OAB of side 12 cm as centre.

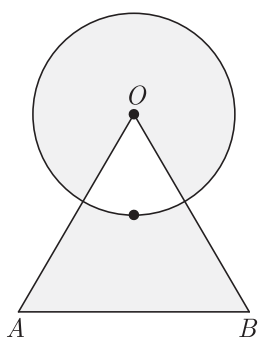

- (a) $12\sqrt{3} + \frac{142}{7}$ (b) $24\sqrt{3} - \frac{142}{7}$
 (c) $36\sqrt{3} + \frac{528}{7}$ (d) $24\sqrt{3} + \frac{142}{7}$

37. A wire when bent in the form of an equilateral triangle encloses an area of $121\sqrt{3}$ cm². If the wire is bent in the form of a circle, what is the area enclosed by the circle? Use $\pi = \frac{22}{7}$.

- (a) 246.5 cm² (b) 620.5 cm²
 (c) 921.5 cm² (d) 346.5 cm²

38. If α and β are the zeroes the polynomial $2x^2 - 4x + 5$, the value of $\alpha^2 + \beta^2$ is

- (a) 2 (b) 1
 (c) -1 (d) -6

39. In the fig., ABC is a right-angle triangle, $\angle B = 90^\circ$, $AB = 28$ cm and $BC = 21$ cm. With AC as diameter, a semi-circle is drawn and with BC as radius a quarter circle is drawn. What is the area of the shaded region?

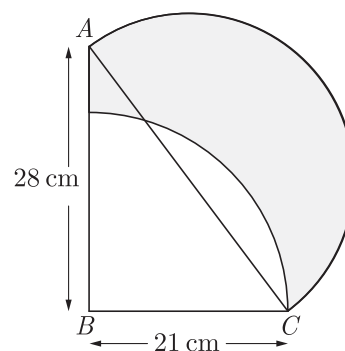

- (a) 596.75 cm² (b) 428.75 cm²
 (c) 520.75 cm² (d) 496.75 cm²

40. In Figure, $ABCD$ is a rectangle. The values of x and y will be

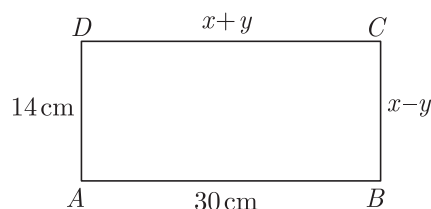

- (a) 20 cm (b) 24 cm
 (c) 22 cm (d) 18 cm

SECTION C

Case study based questions:

Section C consists of 10 questions of 1 mark each. Any 8 questions are to be attempted.

Case Based Questions: (41-45)

Masks are an additional step to help prevent people from getting and spreading COVID-19. They provide a barrier that keeps respiratory droplets from spreading. Wear a mask and take every day preventive actions in public settings.



Due to ongoing Corona virus outbreak, Wellness Medical store has started selling masks of decent quality. The store is selling two types of masks currently type A and type B .

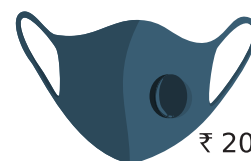

The cost of type A mask is Rs. 15 and of type B mask is Rs. 20. In the month of April, 2020, the store sold 100 masks for total sales of Rs. 1650.

41. How many masks of each type were sold in the month of April?

- (a) 40 masks of type A , and 60 masks of type B
 (b) 60 masks of type A , and 40 masks of type B

- (c) 70 masks of type *A*, and 30 masks of type *B*
 (d) 30 masks of type *A*, and 70 masks of type *B*

42. If the store had sold 50 masks of each type, what would be its sales in the month of April?
 (a) ₹ 550 (b) ₹ 560
 (c) ₹ 1050 (d) ₹ 1750
43. Due to great demand and short supply, the store has increased the price of each type by Rs. 5 from May 1, 2020. In the month of May, 2020, the store sold 310 masks for total sales of Rs. 6875. How many masks of each type were sold in the month of May?
 (a) 175 masks of type *A*, and 135 masks of type *B*
 (b) 200 masks of type *A*, and 110 masks of type *B*
 (c) 110 masks of type *A*, and 200 masks of type *B*
 (d) 135 masks of type *A*, and 175 masks of type *B*
44. What percent of masks of each type sale was increased in the month of May, compared with the sale of month April?
 (a) 110% in type *A* and 180% in type *B*
 (b) 180% in type *A* and 110% in type *B*
 (c) 350% in type *A* and 150% in type *B*
 (d) 150% in type *A* and 350% in type *B*
45. What extra profit did store earn by increasing price in May month.
 (a) ₹ 1550 (b) ₹ 3100
 (c) ₹ 1650 (d) ₹ 1825

Case Based Questions: (46-50)

Tower cranes are a common fixture at any major construction site. They're pretty hard to miss -- they often rise hundreds of feet into the air, and can reach out just as far. The construction crew uses the tower crane to lift steel, concrete, large tools like acetylene torches and generators, and a wide variety of other building materials.

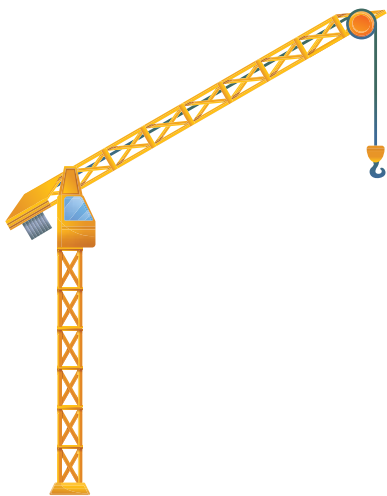

A crane stands on a level ground. It is represented by a tower *AB*, of height 24 m and a jib *BR*. The jib is of length 16 m and can rotate in a vertical plane about *B*. A vertical cable, *RS*, carries a load *S*. The diagram shows current position of the jib, cable and load.

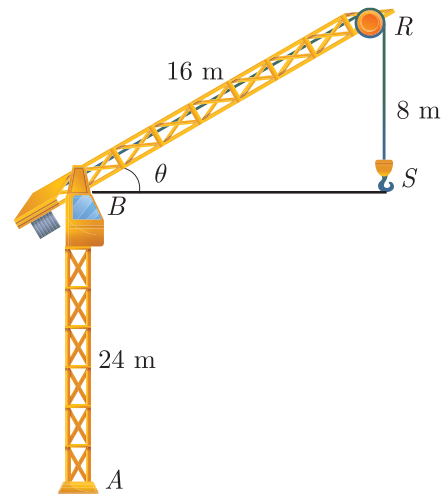

46. What is the distance *BS*?
 (a) $8\sqrt{3}$ m (b) $4\sqrt{3}$ m
 (c) $4\sqrt{2}$ m (d) $8\sqrt{2}$ m
47. What is the angle that the jib, *BR*, makes with the horizontal?
 (a) 45° (b) 30°
 (c) 60° (d) 75°
48. What is the measure of the angle *BRS*?
 (a) 60° (b) 75°
 (c) 30° (d) 45°
49. Now the jib *BR*, has been rotated and the length *RS* is increased. The load is now on the ground at a point 8 m from *A*. What is the angle through which the jib has been rotated?
 (a) 15° (b) 25°
 (c) 30° (d) 45°
50. What is the length by which *RS* has been increased?
 (a) $8\sqrt{3}$ m (b) $8(\sqrt{3} + 2)$ m
 (c) $8(\sqrt{3} + 1)$ m (d) $4(\sqrt{3} + 2)$ m

SAMPLE PAPER - 10 Answer Key

Paper Q. no.	Correct Option	Chapter no	Question Bank Q. no.
1	(a)	Ch-1	37
2	(d)	Ch-3	17
3	(b)	Ch-4	37
4	(c)	Ch-4	63
5	(d)	Ch-8	26
6	(d)	Ch-4	47
7	(b)	Ch-6	28
8	(d)	Ch-1	23
9	(b)	Ch-3	32
10	(b)	Ch-5	24
11	(b)	Ch-2	33
12	(c)	Ch-1	S-23
13	(a)	Ch-6	63
14	(a)	Ch-6	S-15
15	(c)	Ch-7	20
16	(b)	Ch-4	44
17	(d)	Ch-4	S-128
18	(d)	Ch-6	97
19	(a)	Ch-3	S-5
20	(c)	Ch-8	34
21	(c)	Ch-1	S-27
22	(c)	Ch-5	18
23	(b)	Ch-6	103
24	(b)	Ch-3	40
25	(a)	Ch-2	S-13

Paper Q. no.	Correct Option	Chapter no	Question Bank Q. no.
26	(b)	Ch-8	96
27	(a)	Ch-8	78
28	(a)	Ch-6	105
29	(d)	Ch-5	56
30	(b)	Ch-4	S-147
31	(a)	Ch-5	78
32	(d)	Ch-6	92
33	(d)	Ch-1	S-24
34	(a)	Ch-4	53
35	(a)	Ch-5	48
36	(c)	Ch-7	57
37	(d)	Ch-7	68
38	(c)	Ch-2	S-11
39	(b)	Ch-7	81
40	(c)	Ch-3	68
41	(c)	Ch-3	153
42	(d)	Ch-3	154
43	(a)	Ch-3	155
44	(d)	Ch-3	156
45	(a)	Ch-3	157
46	(a)	Ch-6	150
47	(b)	Ch-6	151
48	(a)	Ch-6	152
49	(c)	Ch-6	153
50	(b)	Ch-6	154

* S - Self Test Question